

WQB 4000SOPS - Quick Starter Guide

From software version 2.17

1.3 Check the computer system

- System requirements: Pentium 4 / Athlon 64 CPU or newer, CD-ROM, min. 1024 MB RAM,
- Operating system: Windows 2000 SP4, XP SP2, Vista 32-Bit, 7 32Bit & 64Bit
- Screen resolution min.1280 x 1024, min. 16 bit colour depth
- 2 free USB 2.0 full powered (500 mA) interfaces
- Graphic card with DirectX 9.29 Support

3.1 Installation of drivers and software

- Important! In order to install the software, you must have **Administrator rights**. **The device must not be connected.**
- **To avoid installation conflicts, older drivers should be deinstalled and the SILABS USB driver should be removed**
- Inserted the software CD included in the delivery in the drive. The Installation Assistant will guide you through the installation. Open the "SOFTWARE" tab.



- Opening the "SOFTWARE" tab

STEP 1, SILABS USB driver. Follow the instructions



To avoid installation conflicts, remove older versions of the SiLabs USB driver

STEP 2, uEye camera driver. Follow the instructions.



Choose the right uEye Driver depending on the version of your operating system (32Bit/64Bit).

It is required, that you have installed the right Version of the uEye driver, which is delivered with the WQB 4000 Software.

WQB 400SOPS - Quick Starter Guide

From software version 2.17

STEP 3 DirectX 9.29 Redist Follow the instructions.



Install DirectX 9.29 even if a higher version of DirectX (10/11) is installed

STEP 4 WQB400 Software Follow the instructions.



Restart your PC after installation

Change the Settings of the CPU idle states

Start "IDS Camera Manager.exe"

Press "Additional functions" button

Disable the CPU idle states (Hook in box).

Close the window

Firmware Update

The installation of the firmware updater is not necessary for correct operation of the device; installation of this software is therefore only recommended if required.

2.3 Assembly / installation instructions

- 2.3 a Required table area 1030 X 630 X 650 cm for a load of approx. 40 Kg
- 2.3.b Place the device in the middle of the table
- 2.3.c Set the adjustable feet with the air level so that the device is horizontal and does not wobble.

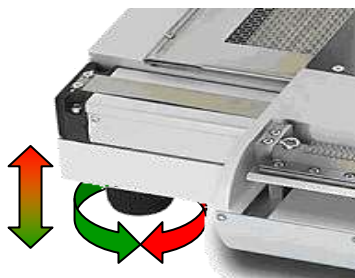

WQB 400SOPS - Quick Starter Guide

From software version 2.17

2.3.1 Assembly of the split optical unit

The optical module is already pre-calibrated in the factory. It therefore only needs to be assembled, checked and readjusted as required.

2.3.1.a Assembly: push the linear axis to the right-hand stop.

2.3.1.b Flange-mount the optical module and secure with 3 stud bolts from the rear and tighten to a torque of 2 Nm

2.3.1.c Insert connector for optical unit lighting

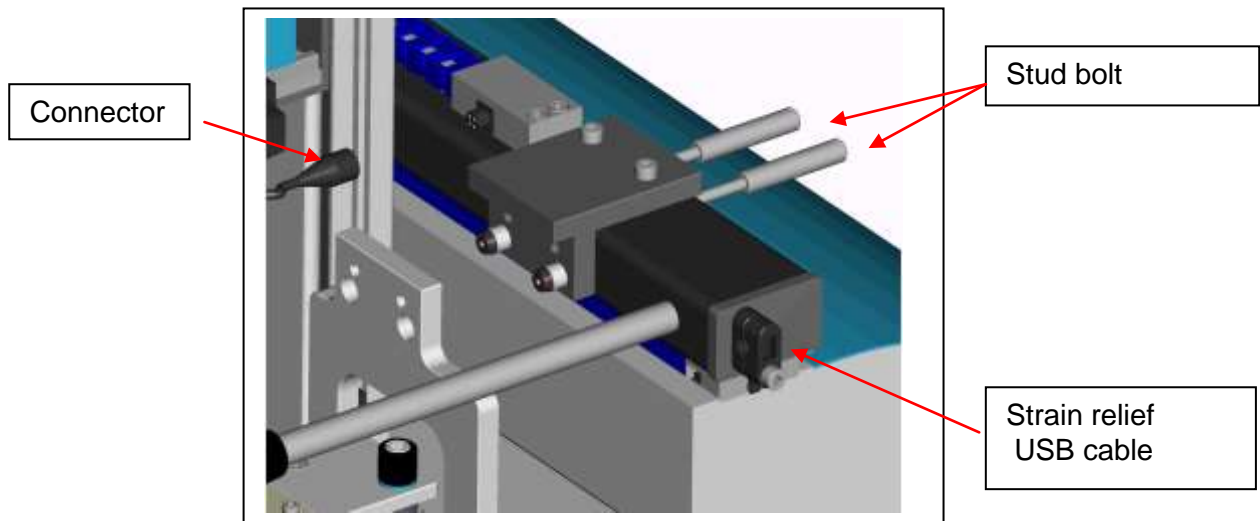

2.3.2 Connection of the device

Mains voltage: observe the specifications on the type plate

Compressed air: 400 – 600 kPa **pure, dry** and **oil-free** compressed air (where possible, with upstream maintenance unit)

Alternative: compressed air for vacuum generation, nitrogen (N₂) for the soldering process

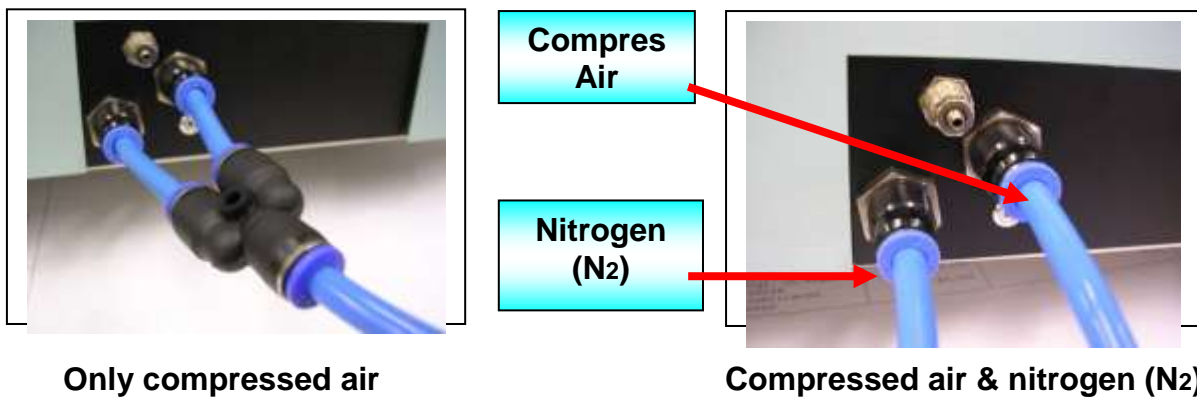

WQB 4000SOPS - Quick Starter Guide

From software version 2.17

3.2 USB ports

Important!

The WQB 4000SOPS only operates reliably with the shielded USB cables included in the accessories.

Camera: connect directly with a **USB 2.0 - full powered** – interface

WQB4000 : connect directly with a **USB 2.0 - full powered** interface

3.2.1 Initial operation of the software

- Switch on the WQB 4000SOPS
- PC ► START ► Programs ► Cooper Tools ► WQB4000SOPSControl
- The device starts with default settings
- The soldering head must be raised and the split optical unit must be at the right-hand stop.
- The reference run for table and insertion head is started with the "GO" command.



This procedure is necessary every time the device is restarted!

WQB 4000SOPS - Quick Starter Guide

From software version 2.17

3.3 Check of the split optical unit

Placement

- In order to calibrate, the **Placement** tab must be opened and the table must be in **Placement position**
- Insert the calibration template in the PCB holder and activate the frame or cross-hairs
- Align calibration template centrally in relation to the faded in frame or cross-hairs (clamping screws of the PCB holder ⑤ , micrometer screw ⑥)
- Place component in template; the optical unit is at the left-hand stop
- Align insertion head with ⑧⑨ centrally in relation to component
- Move optical unit to right-hand stop (green LED)
- Activate Automatic mode in the Z-axis drive
- Set Pos.** is used to lower the insertion head, automatically pick up the component and to move to **Align Pos.**
- Important. Following this, the vacuum pick-up alignment must not be changed!**
- Move optical unit to the left
- Use ▲ or ▼ to adapt component and template to same size
- The red and blue dots must now be flush.
- If the dots are not in alignment, the optical unit must be calibrated

EXIT

Auto Stop

Reference Axis

Exit Vacuum

Solderhead

Soldering pos.

Component Pos.

Center Pos.

Placement Pos.

Head Position I

775,250

Head Position II

775,250

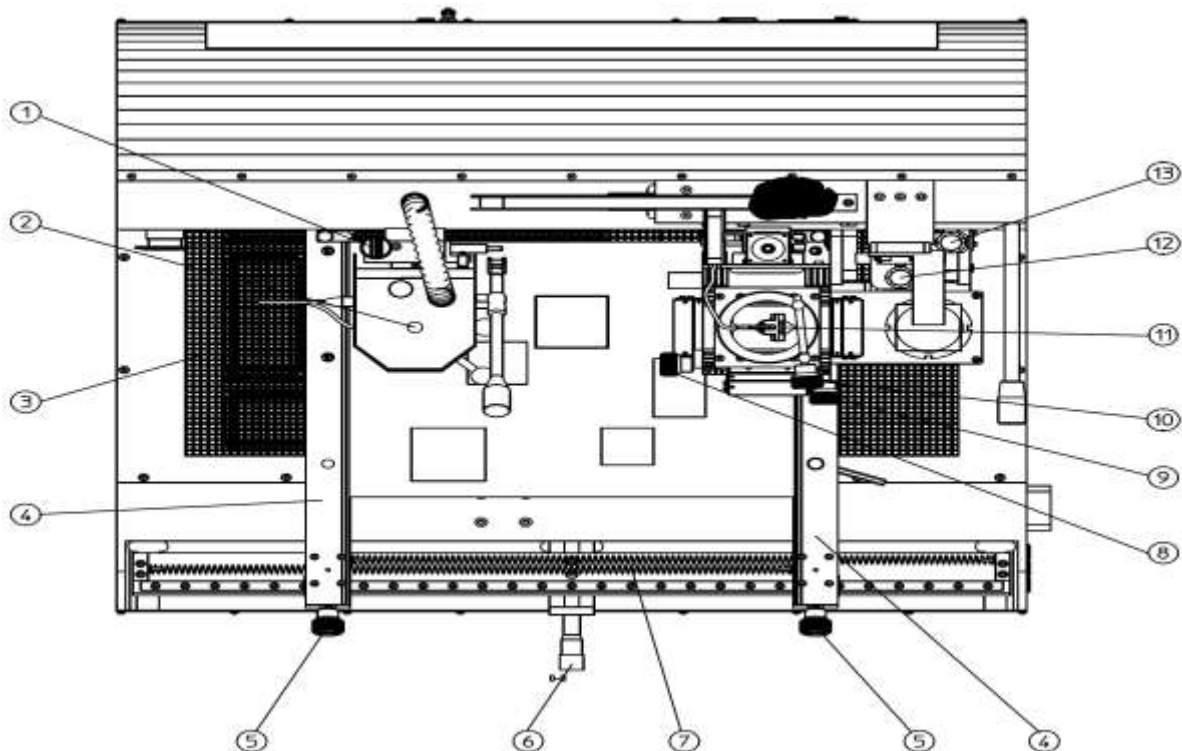

WQB 4000SOPS - Quick Starter Guide

From software version 2.17

3.4 Check of the split optical unit

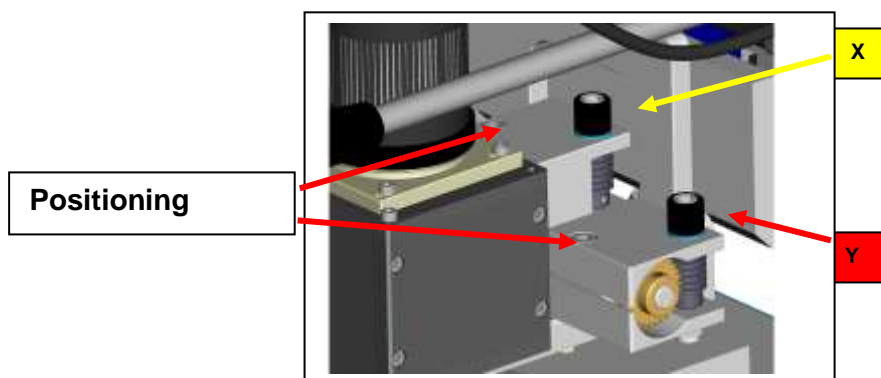
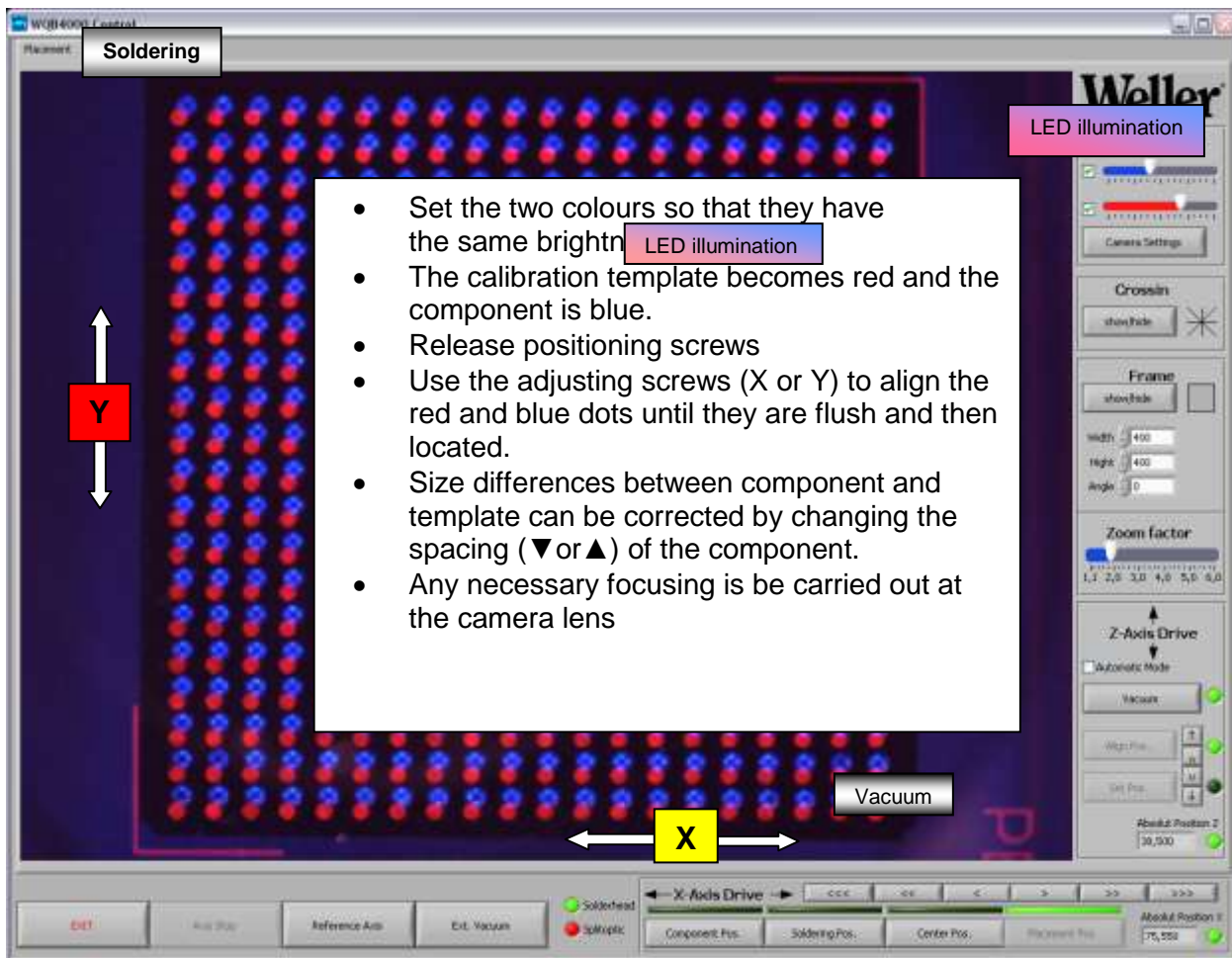

- To check the optical unit calibration, the optical unit is moved out to the right (green LED), the component is set down and the insertion head is moved to Align Position.
- Insert component in template and pick up manually or in Automatic mode. The optical unit is moved to the left. Following this, the red and blue dots must be flush once again.

WQB 4000SOPS - Quick Starter Guide

From software version 2.17

Loading nozzle parameters or profiles

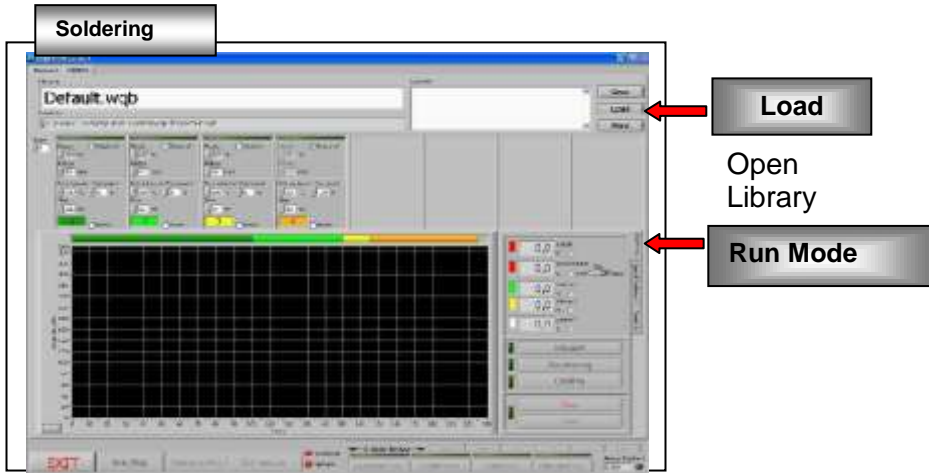

When the software is started, the last profile used is opened up.

1. Loading existing profile

- Open desired directory
 - leaded
 - lead-free
 - Loading profile

2. Creating new profile

- Select application
- Activate Special Function**



- **Creating new profile**
- **Select desired nozzle size**
(nozzle 27 x 27)

→ OK

- Gradient (default 2K/sec) →
- on/off**

- Activate Automatic Teach-In
- Define Teach-in temperatures in the individual steps
- Place sensors and define Teach-in sensor

WQB 4000SOPS - Quick Starter Guide

From software version 2.17

Loading nozzle parameters or profiles



- Start desoldering
- Desolder component, profile and write
- Clean pc board
- Open tab **Placement** and insert new component and align manually. Correct the component size if necessary with the height adjustment, define Z-axis stop.
- Save profile under the desired file name. The settings will also be saved in this profile for subsequent use.